

Glider

144 LED/m • 44 LED/ft

10,0 W/m • 3,1 W/ft

168 LED/m • 52 LED/ft

15,0 W/m • 4,6 W/ft

182 LED/m • 56 LED/ft

20,0 W/m • 6,1 W/ft

TW - 252 LED/m • 77 LED/ft Tunable White

20,0 W/m • 6,1 W/ft

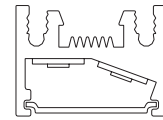
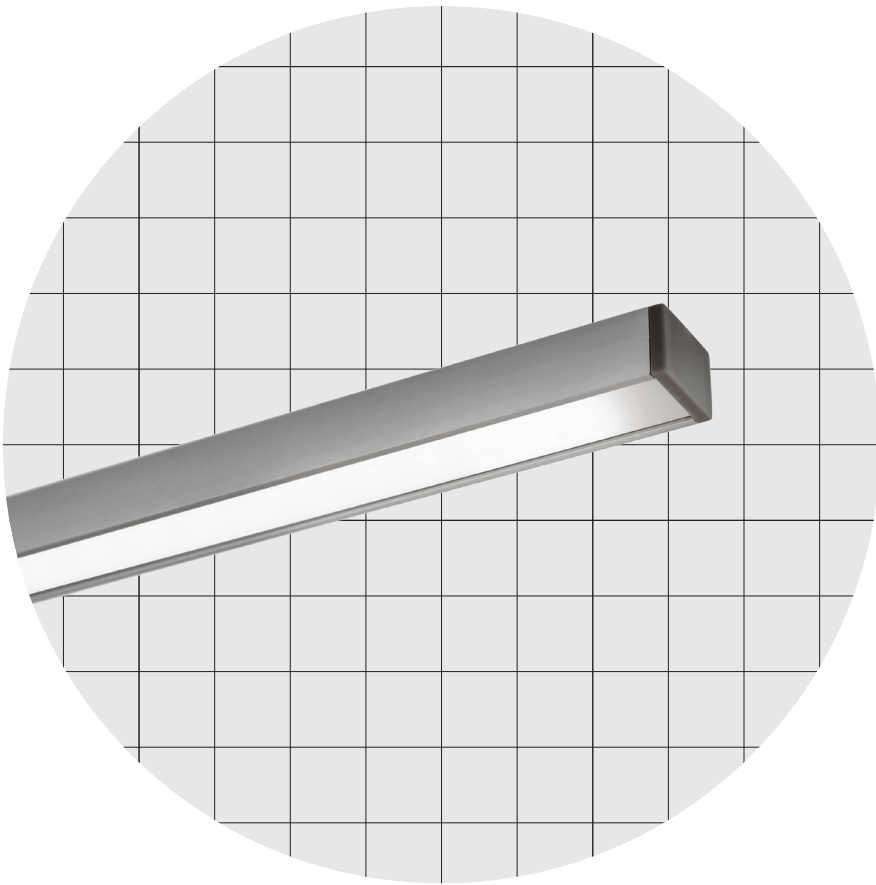

20,0 mm × 15,0 mm
0,78 " × 0,59 "

Glider



Sharp Asym.

Body Corpo

Linear asymmetric profile

Profilo lineare asimmetrico

Fastening Fissaggio	Caps + Plastic clips Caps + Magnets	Tappi + Clip in plastica Tappi + Magneti
-------------------------------	--	--

Screen Schermo	Transparent TR7 (Screening 7%) Opal OP30 (Screening 30%) Opal OP50 (Screening 50%)	Trasparente TR7 (Schermatura 7%) Opale OP30 (Scherm. 30%) Opale OP50 (Scherm. 50%)
--------------------------	---	---

Wiring set Cavo alimentazione	2000 mm • 78,74 "	2000 mm
---	-------------------	---------

Custom size Lunghezza ordinabile	Up to 3000 mm • 118,10 "	Fino a 3000 mm
--	-----------------------------	----------------

Finishing Finitura	● Grey anodized	● Anodica grigia
------------------------------	-----------------	------------------

Listings and marks
Certificazioni e marchi

LED
LED



Light Luce

	144 LED/m • 44 LED/ft	168 LED/m • 52 LED/ft	182 LED/m • 56 LED/ft	TW - 252 LED/m • 77 LED/ft Tunable White
Light source Sorgente luminosa				
Power consumption Consumo energia	10,0 W/m • 3,1 W/ft	15,0 W/m • 4,6 W/ft	20,0 W/m • 6,1 W/ft	20,0 W/m • 6,1 W/ft
CCT K	● 2700 K ● 3000 K ● 3500 K ● 4000 K ● 5000 K	● 2700 K ● 3000 K ● 3500 K ● 4000 K ● 5000 K	● 2700 K ● 3000 K ● 3500 K ● 4000 K ● 5000 K	● 2200 - 5700 K
Mixing on demand Miscelazione su richiesta				
CRI R9 Rf @ 3000 K Rg @ 3000 K MacAdam ellipse	Min 90 Min 50 92 100 3	Min 90 Min 50 92 100 3	Min 90 Min 50 92 100 3	Min 90 Min 50 92 100 3
Luminous flux Flusso luminoso ● 3000 K	↓ A - TR5 - 104 lm/W 1040 lm/m • 317 lm/ft ↓ A - OP20 - 72 lm/W 715 lm/m • 218 lm/ft ↓ A - OP50 - 59 lm/W 585 lm/m • 178 lm/ft	↓ A - TR5 - 112 lm/W 1692 lm/m • 516 lm/ft ↓ A - OP20 - 77 lm/W 1163 lm/m • 355 lm/ft ↓ A - OP50 - 63 lm/W 951 lm/m • 290 lm/ft	↓ A - TR5 - 131 lm/W 2624 lm/m • 800 lm/ft ↓ A - OP20 - 90 lm/W 1804 lm/m • 550 lm/ft ↓ A - OP50 - 73 lm/W 1476 lm/m • 450 lm/ft	↓ A - TR5 - 72 lm/W 1440 lm/m • 439 lm/ft ↓ A - OP20 - 50 lm/W 990 lm/m • 302 lm/ft ↓ A - OP50 - 41 lm/W 810 lm/m • 247 lm/ft
Luminous flux Flusso luminoso ● 3000 K	↓ B - TR5 - 104 lm/W 1040 lm/m • 317 lm/ft ↓ B - OP20 - 69 lm/W 689 lm/m • 210 lm/ft ↓ B - OP50 - 52 lm/W 520 lm/m • 159 lm/ft	↓ B - TR5 - 112 lm/W 1692 lm/m • 516 lm/ft ↓ B - OP20 - 74 lm/W 1120 lm/m • 341 lm/ft ↓ B - OP50 - 56 lm/W 846 lm/m • 258 lm/ft	↓ B - TR5 - 131 lm/W 2624 lm/m • 800 lm/ft ↓ B - OP20 - 87 lm/W 1738 lm/m • 530 lm/ft ↓ B - OP50 - 65 lm/W 1312 lm/m • 400 lm/ft	↓ B - TR5 - 72 lm/W 1440 lm/m • 439 lm/ft ↓ B - OP20 - 48 lm/W 954 lm/m • 291 lm/ft ↓ B - OP50 - 36 lm/W 720 lm/m • 220 lm/ft
Input voltage Tensione di ingresso	24 V DC	24 V DC	24 V DC	24 V DC

Glider

Dimensions Dimensioni

Scale/Scala 1:1

TA Caps + Plastic clips Tappi + Clip in plastica

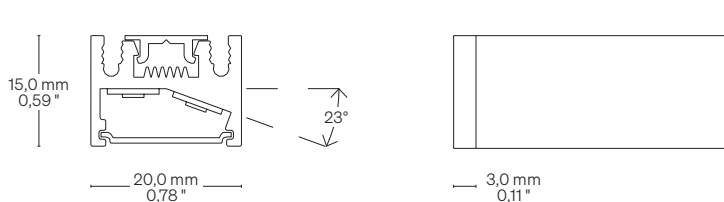

TAM Caps + Magnets Tappi + Magneti

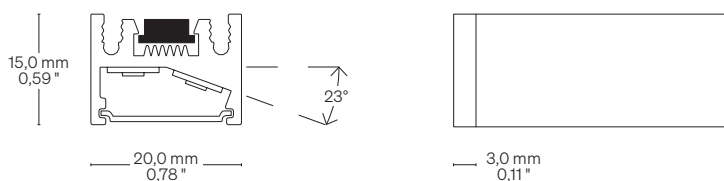

Strip LED position Posizione strip LED

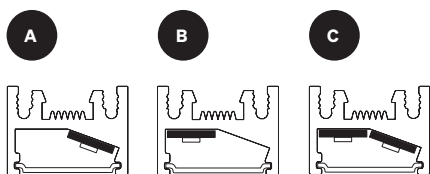

C. With this configuration of the stripes, there are limitations on the maximum power usable.

C. Per questa configurazione ci sono delle limitazioni riguardo alla potenza massima utilizzabile.

Fastening options Opzioni di fissaggio

TA Caps + Plastic clips Tappi + Clip in plastica

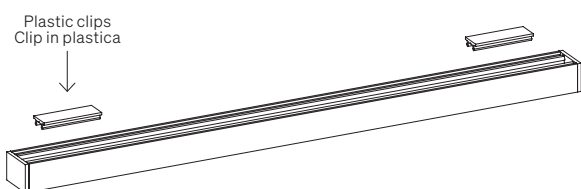

TAM Caps + Magnets Tappi + Magneti

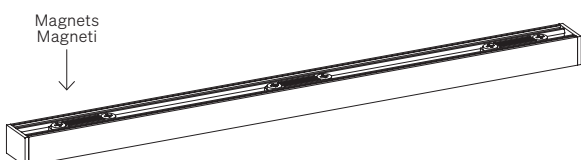

Order code Codice ordine

Basic code Codice base	<ul style="list-style-type: none"> GLF144 Glider 144 LED/m • 44 LED/ft 10,0 W/m • 3,1 W/ft GLF168 Glider 168 LED/m • 52 LED/ft 15,0 W/m • 4,6 W/ft GLF182 Glider 182 LED/m • 56 LED/ft 20,0 W/m • 6,1 W/ft GLF252 Glider TW 252 LED/m • 77 LED/ft ● 2200 - 5700 K 20,0 W/m • 6,1 W/ft
CCT K CCT K	<ul style="list-style-type: none"> WW27 ● 2700 K WW30 ● 3000 K NW35 ● 3500 K NW ● 4000 K CW ● 5000 K
Strip LED position Posizione strip LED	<ul style="list-style-type: none"> A Side Laterale B Zenith. On the plane Zenitale. Sul piano C Double strip LED Doppia strip LED
Fastening options Opzioni di fissaggio	<ul style="list-style-type: none"> TA Caps + Plastic clips Tappi + Clip in plastica TAM Caps + Magnets Tappi + Magneti
Screen Schermo	<ul style="list-style-type: none"> TR7 Transparent/Trasparente 7 OP30 Opal/Opale 30 OP50 Opal/Opale 50
Custom size Lunghezza ordinabile	<ul style="list-style-type: none"> -- Specify the size Specificare la misura
Order example Esempio ordine	<ul style="list-style-type: none"> GLF144 WW27 A TA TR7 • 0,32 Glider, 144 LED/m • 44 LED/ft, 10,0 W/m • 3,1 W/ft, Warm White 2700, Side, Caps + Plastic clips, Transparent 7 • 0,32 m Glider, 144 LED/m, 10,0 W/m, Warm White 2700, Laterale, Tappi + Clip in plastica, Trasparente 7 • 0,32 m

Cable outlet Uscita cavi

Left side Lato sinistro

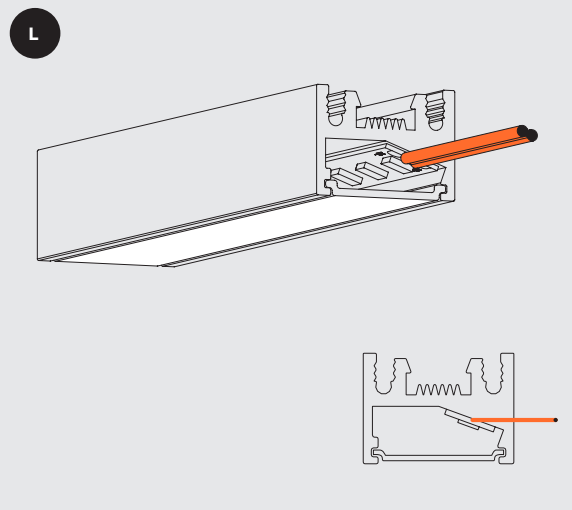

Right side Lato destro

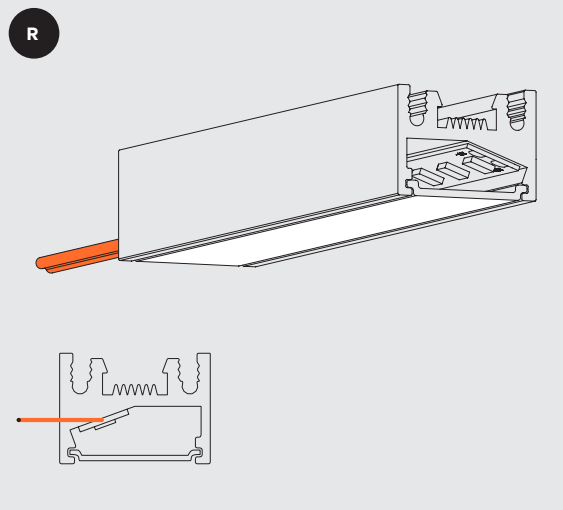

Warnings Avvertenze

The installation of the product, must be done as illustrated in the catalogue or inside the technical data-sheet that can be asked to the manufacturer. An installation performed differently from the one indicated may compromise the durability and characteristics of the product itself.

An installation performed differently from the one indicated may compromise the durability and characteristics of the product.

Unsuitable cross-section / length of the cable can negatively affect the lighting power of the product. If Power supplies, even those with a plastic case, are located in spaces that are too small for their dimensions; they will be subjected to dissipation problems that will compromise their functionality. Silicones or resins subjected to temperature changes and used near the product, if not in accordance with the specifications issued by the manufacturer, they can seriously damage the LED component. The products can not be modified without any authorization by the manufacturer.

L'installazione del prodotto, dovrà eseguirsi come illustrato nel catalogo o nella documentazione tecnica richiedibile al produttore. Un'installazione eseguita diversamente da quella indicata, può compromettere la durata e le caratteristiche del prodotto.

Prima dell'installazione verificare la corretta sezione del cavo collegato tra LED e alimentatore.

Sezione / lunghezza del cavo non congrui, possono alterare in negativo la luminosità del prodotto. Gli alimentatori, anche quelli con contenitore plastico, inseriti in spazi troppo piccoli, saranno soggetti a problemi di dissipazione che comprometteranno la loro funzionalità. Siliconi o resine soggetti a sbalzi di temperature e utilizzati in prossimità del prodotto, se non conformi alle specifiche rilasciate dal produttore possono danneggiare gravemente il componente LED. I prodotti non possono essere modificati senza autorizzazione da parte del produttore.